

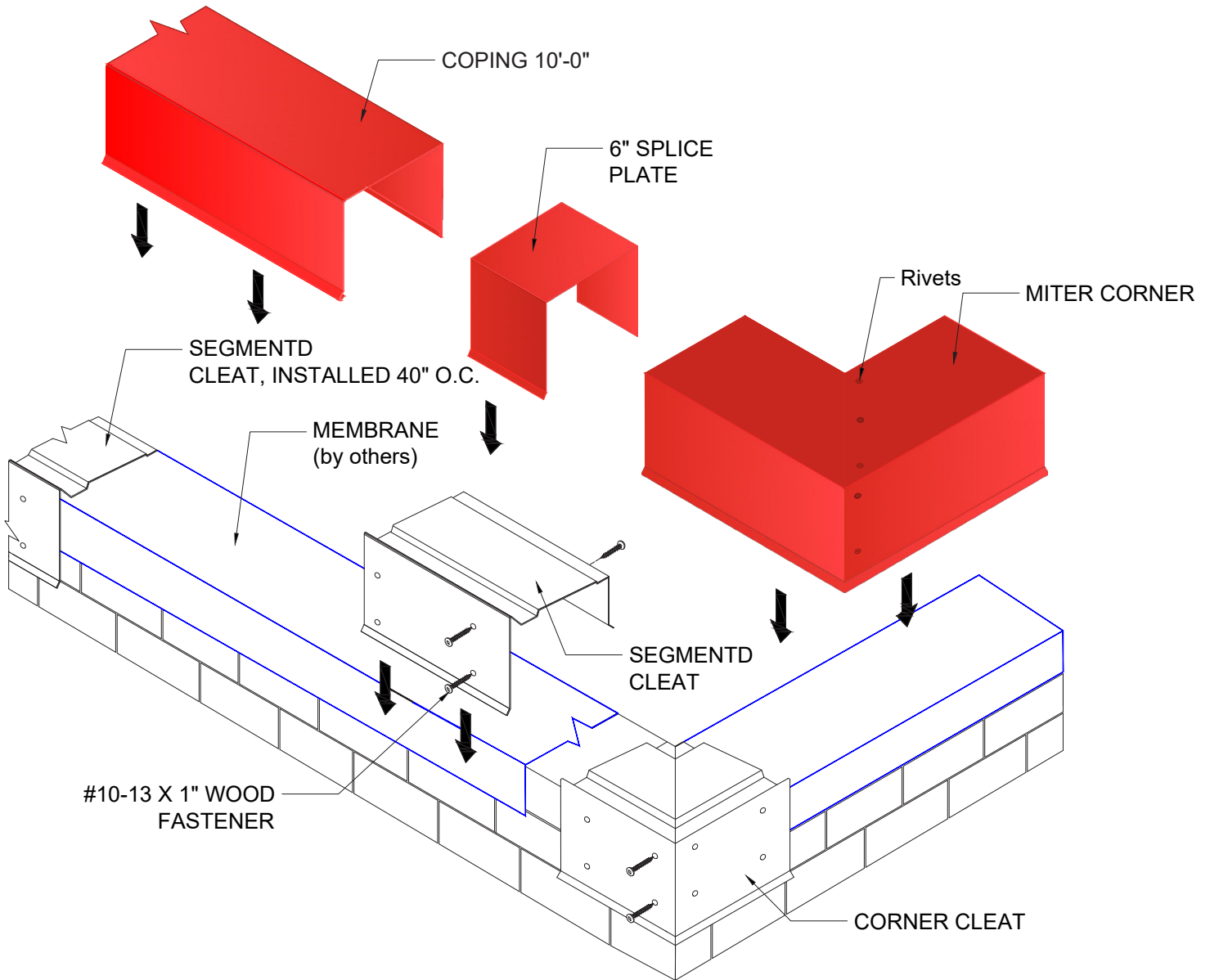

PERMAEDGE MANUFACTURED BY PRACTICAL METALS

PERMAEDGE COPING 4 INSTALLATION INSTRUCTIONS



NOTE: REMOVE PROTECTIVE FILM BEFORE INSTALLATION.

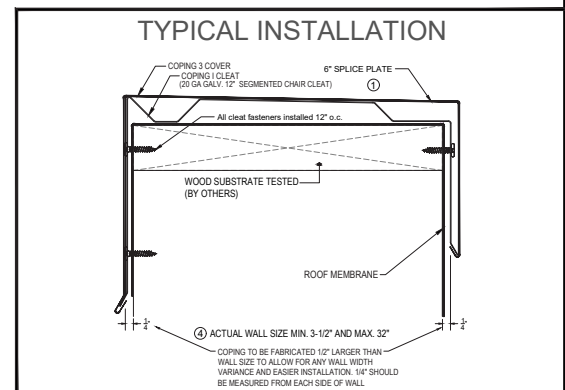

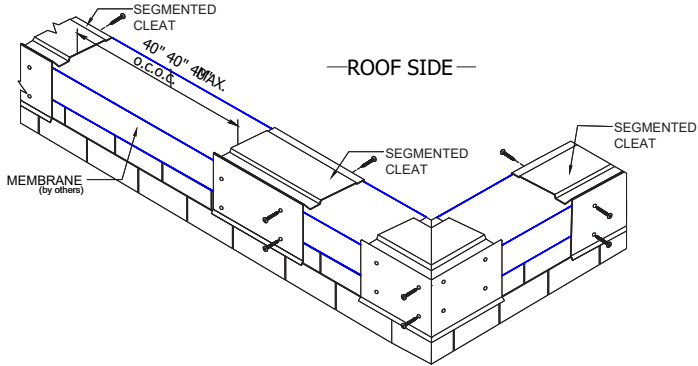

Step 1: Installation using 20 gauge segmented galvanized cleats

Installer needs to ensure to use proper membrane over parapet wall from flat roof manufacturer. You will need to miter your galvanized corner cleats to ensure proper fit. Each corner cleat should have 4 screws on each side of the face and 1 on the back at each side. Remaining cleats are to be installed minimum 40" on center. Each additional cleat is 12" in width and will need 4 screws in front and 2 at the back. #10-13 x 1" GP screws will be provided and are tested. All galvanized cleats are pre-punched.

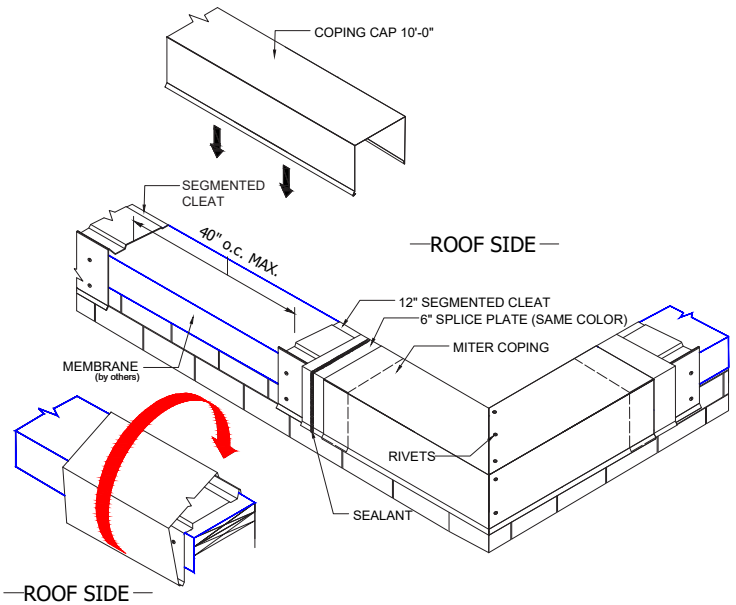

Step 3: Snap-on Coping Installation

Make sure cleats line up with the ends of the coping. Apply a bead of sealant over the 6" provided splice plate. Hook the back on first at roof side, push down at top front of coping so that the front hem of segmented cleat engages to the coping hem. Once you release the coping will be securely attached. All copings by Englert comes in 10'-0" increments.

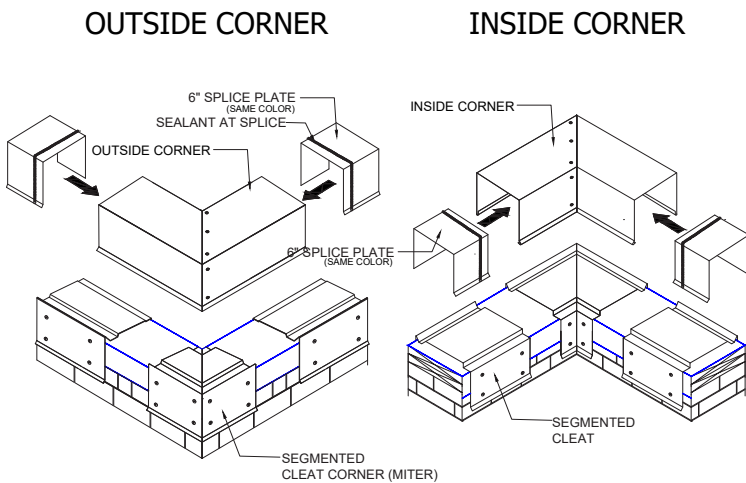

Step 2: Snap-on Miter Corner Installation

Make sure the segmented cleat lines up centered with the ends of the miter. Apply a bead of sealant inside on each end of splice plate. Install splice plate into each end of the miter. Hook miter corner back on first at roof side, push down at top front of miter so that the front hem of segmented cleat engages to the miter hem.

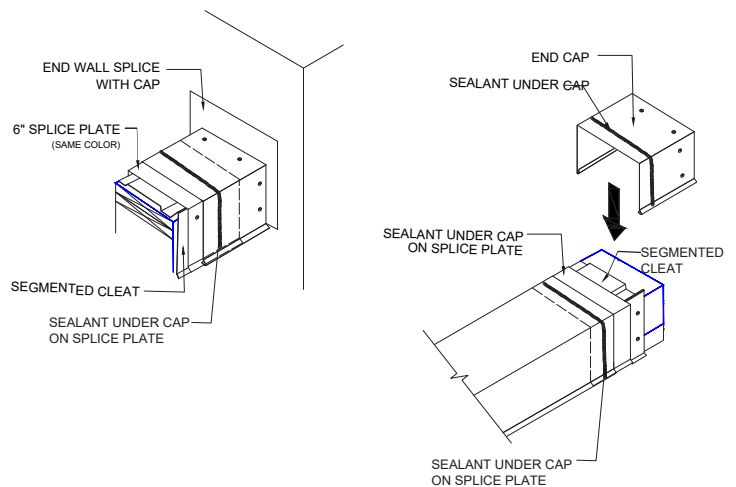

Step 4: Snap-on Coping End Terms & End Caps

Rivet the end cap and end term caps into place. Apply a bead of tube sealant and install a 6" splice plate into the end term or end cap. Install end caps and end terms by hooking the back on first, pushing down at top front of miter so that the front hem of segmented cleat engages to the mite hem.